

SS-120 INLET

SCALE : 1:1

UNIT : mm

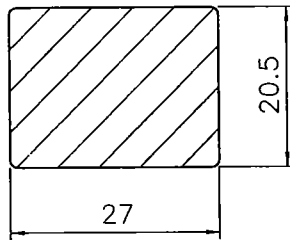
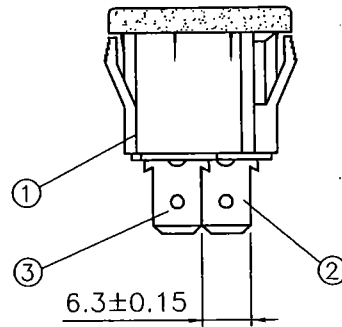
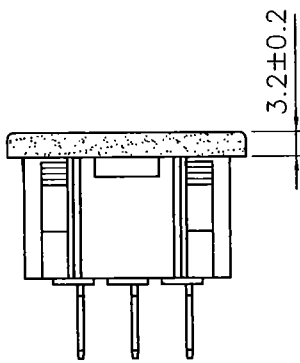
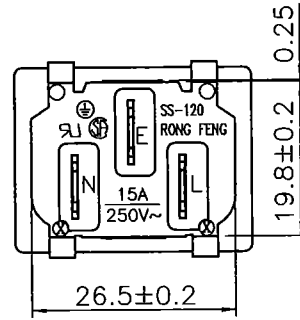
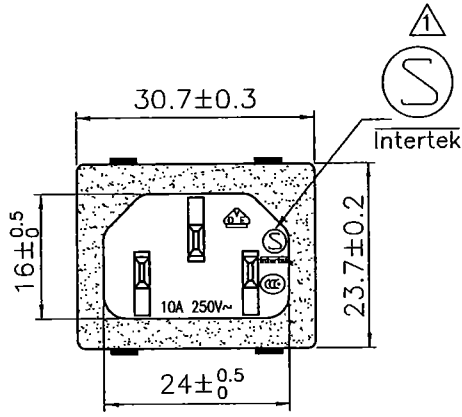

PANEL CUTOUT THICKNESS 0.8mm~1.5mm

Rating: 15A 250V AC
 Approvals: UL/CSA
 Rating: 10A 250V AC
 Approvals: VDE/SEMKO/CCC

Part No.	Color
SS-120-H-6.3	Black
SS-120-H1-6.3	White

			DIMENSIONAL TOLERANCES	
			GRADATION	TOLERANCE
3	Contact PIN Brass Strip t=2mm Ni-Plated	2	X	±0.4
2	Contact PIN Brass Strip t=2mm Ni-Plated	1	X.X	±0.3
1	Body Insulator Nylon PA66	1	X.XX	±0.1
APPROVE: 洪 98.11.27 銘福			ANGLE ±1°	
CHECK: 蔡 98.11.25 伯林			MATERIAL NO: SS-120-H-6.3	
DRAWER: 謝 98.11.27 祺祥			DRAWING NO: 880154	